

SERIES 180 MAXWELL AUTOMATIC BACKFACE TOOL

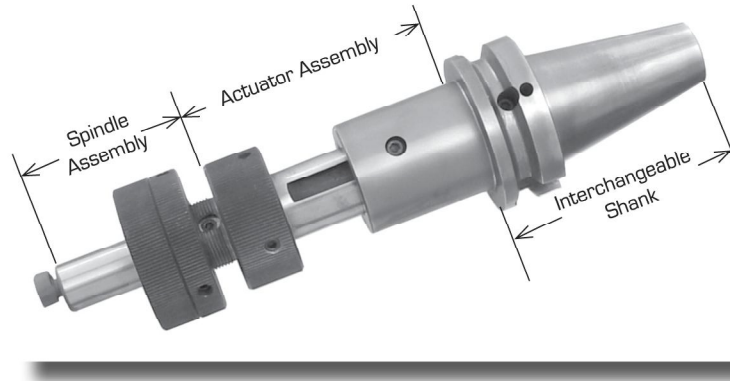

SERIES 180 SHANK OPTIONS

The Shank configuration depends on the machine (or machines) to be used. Series 180 Actuation Assemblies are available with either a removable, interchangeable or fixed shank.

CHOOSING THE CORRECT SPINDLE ASSEMBLY

To match a 180 Series Tool package to your job (or jobs) match the Actuator Assembly from the chart below based on the bore diameter of each application.

As shown in the drawing below, the C, D, E & F dimensions are determined by each application - The ultimate backface cut "F" cannot exceed twice the "E" dimension. The "C" dimension (either bore depth or backface depth) has no practical limit.

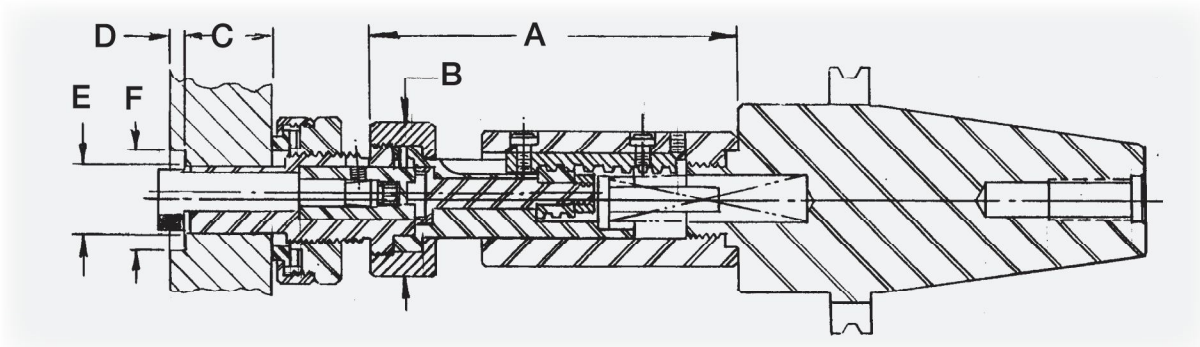

TOOL	APPROXIMATE RANGE / BORE DIAMETER	A	B	C	D	E	F
187	1/4 - 3/4	5 9/16	1 3/4	TO SUIT	TO SUIT	TO SUIT	TO SUIT
188	3/4 - 1 3/4	7 3/16	2 3/4	TO SUIT	TO SUIT	TO SUIT	TO SUIT
189	1 3/4 - 5	11 3/4	3 3/8	TO SUIT	TO SUIT	TO SUIT	TO SUIT

DIMENSIONS ARE IN INCHES